

AFTER SALES SUPPORT WITHOUT QUESTION

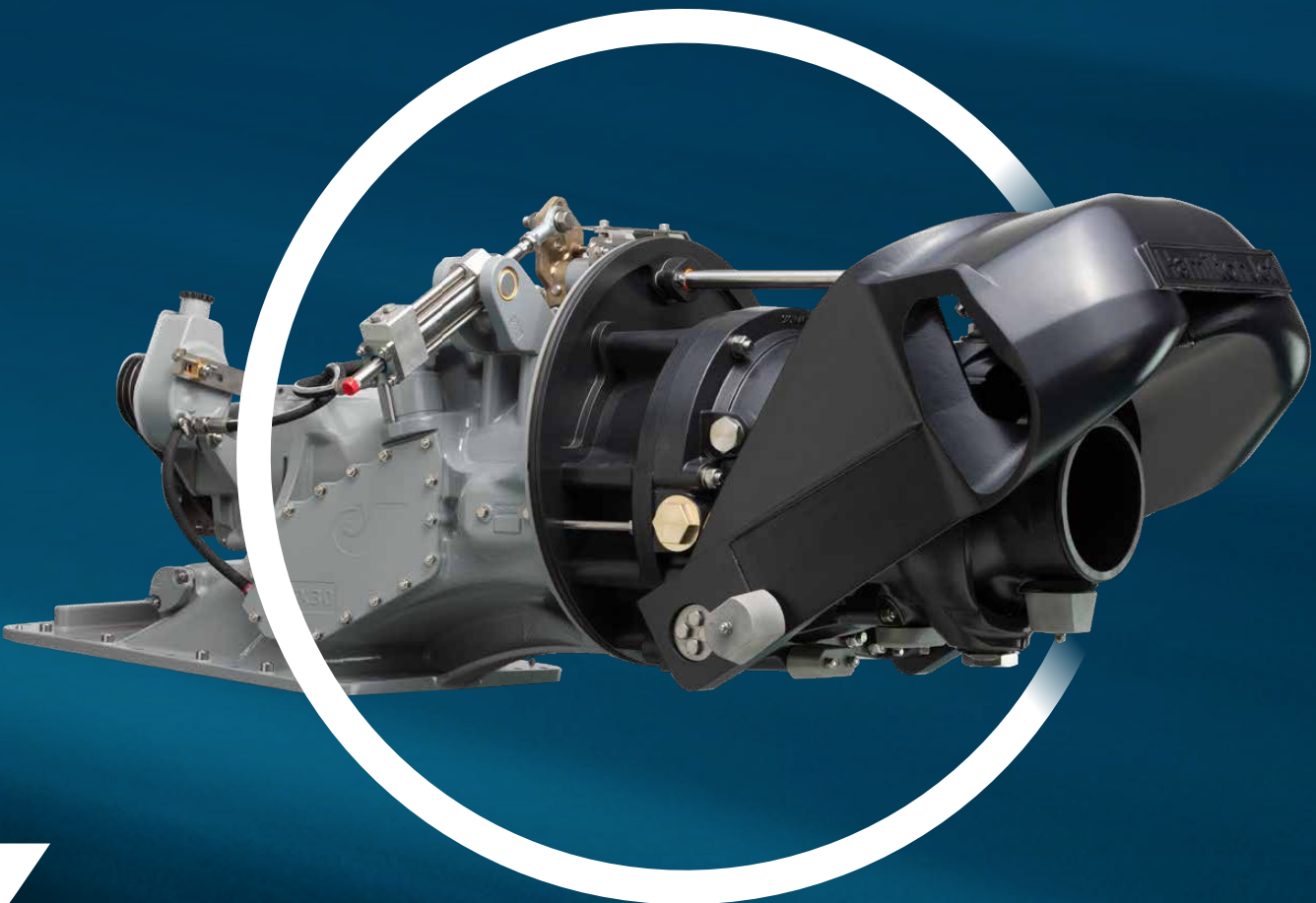

HamiltonJet

The Ultimate in
Waterjet Sophistication

HAMILTONJET THROUGH LIFE SUPPORT

The purchase of a HamiltonJet propulsion and controls solution is the beginning of our journey together.

At HamiltonJet, we pride ourselves on quality and performance, which is carried through our after sales support programmes.

We are committed to ensuring operational uptime is our highest priority.

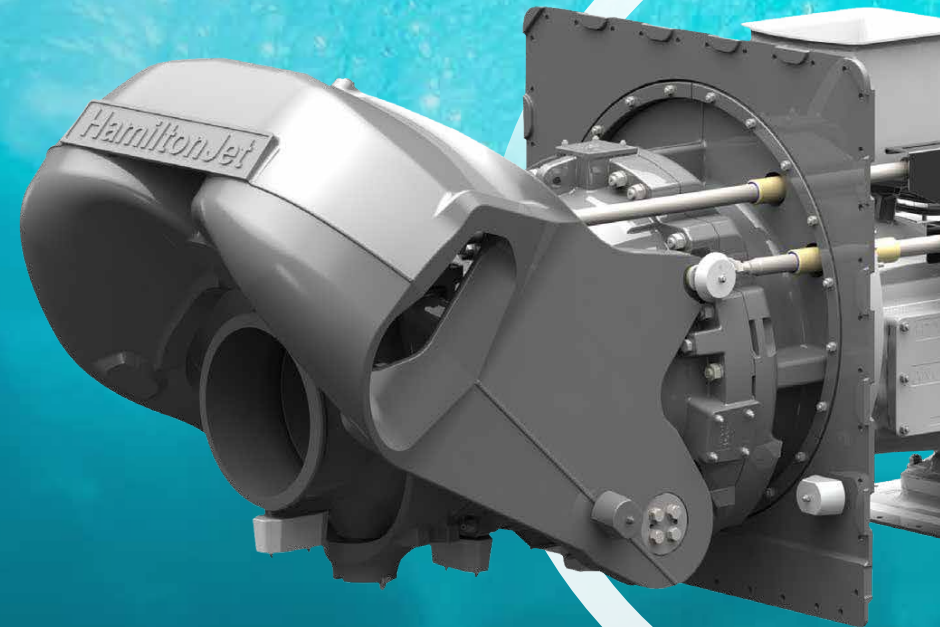



THE HAMILTONJET JOURNEY

Installation

Support and commissioning

Operational Assurance

Maintenance support and training

Retrofit

Refurbishment programmes

Optimisation

Integrating new technologies

WORLD-CLASS PRODUCT SUPPORT

We are backed by more than 70 years in business as the pioneer and market leader in waterjets and controls.

Our product support and parts availability is truly class-leading. With a global network of regional offices and over 50 appointed distributors, help is always on hand. No matter where you are, in the unlikely event of a problem, downtime is minimised.

Our products all come with a commitment to at least 20 years' support after the end of series production*.

*This applies to all HamiltonJet products which reach series production and can be extended longer if a particular project requires it. Beyond this point, we still endeavour to keep you moving where possible.





INSTALLATION AND COMMISSIONING

The HamiltonJet after sales teams are highly skilled in providing the highest quality installation and commissioning support for both mechanical waterjets and controls installations.

With advancements in the AVX and AVXexpress controls networks, we empower our distribution network to provide commissioning services across a broader set of geographies through remote commissioning support programmes.

Regardless of the complexity of your vessel configuration, our technical teams are qualified and experienced to support your unique operational requirements.

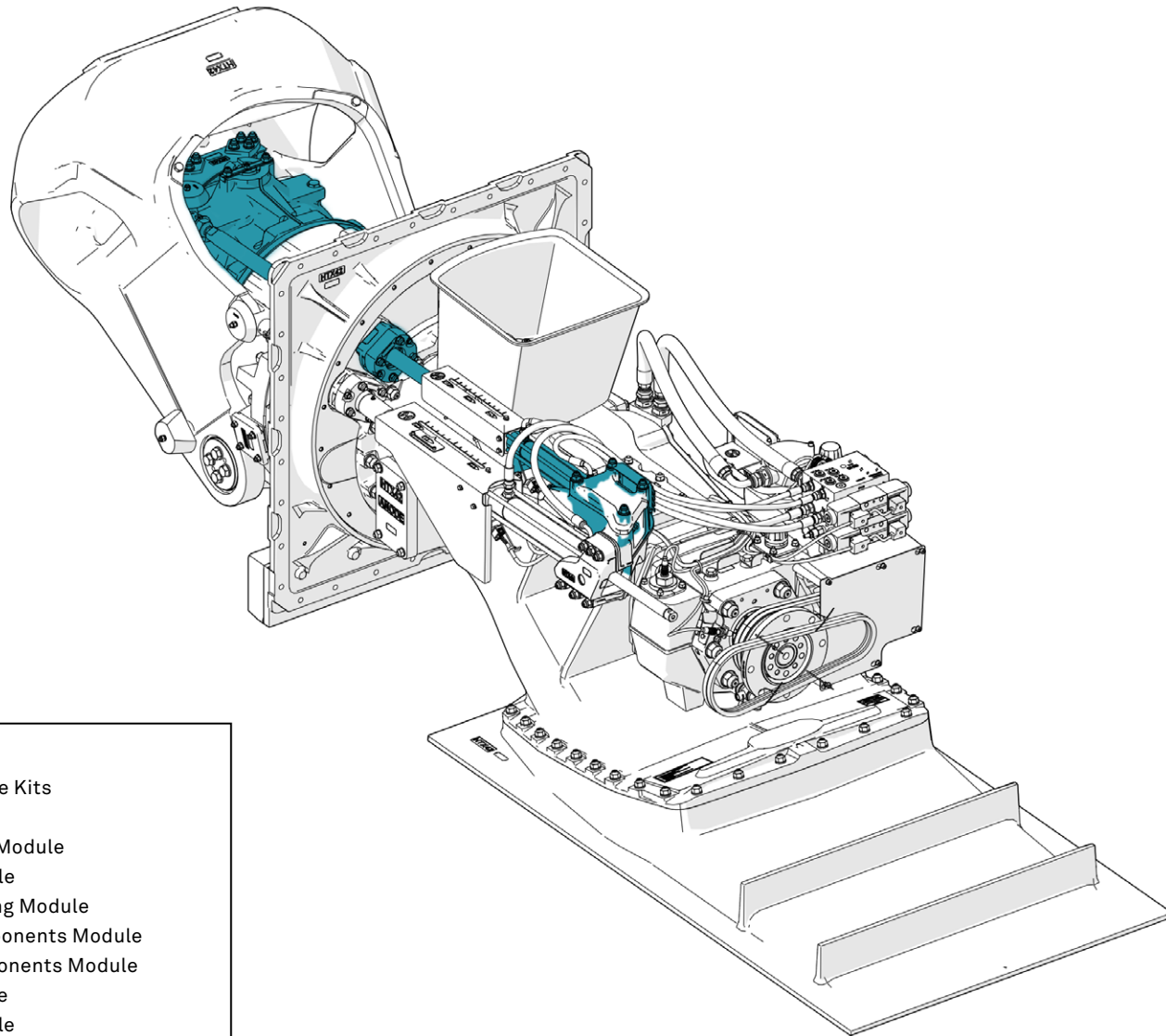

- Routine Service Kits
- Intake Module
- Impeller Race Module
- Transom Module
- Bearing Housing Module
- Coupling Components Module
- Impeller Components Module
- Tailpipe Module
- Steering Module
- Steering Sensor Module
- Reverse Module
- Reverse Sensor Module
- JHPU Module
- Overflow Preventer Kit
- Service Tools

OPERATIONAL ASSURANCE

HamiltonJet has a global population upwards of 60,000 waterjets, providing an unparalleled level of experience in supporting your operational uptime.

With decades of research and development, we design our products to be of the highest quality. However, when things do go wrong our engineers, technical teams and supply chains are ready to respond with a moments notice.

Our Global Distribution Network is designed to support both the planned and unplanned spare parts requirements.

Through life support documents are available for all jet ranges from your regional office. Regular maintenance increases the life of your waterjet.

We are continuing to innovate the way we serve our customers, in turn simplifying the process to provide maintenance for HamiltonJet products. This is through the introduction of the interactive spare parts manuals, standardising routine and non-routine service kits, and introducing new online tools such as the warranty and product registration tools.

FREE TRAINING

At HamiltonJet we consider training one of our highest priorities, and a necessity to providing the highest levels of service.

To ensure that our services are of the highest standards across the globe, we offer specialised training courses to support all levels of experience.

Courses offered include:

- Installation and commissioning training
- Mechanical maintenance training
- Controls maintenance and troubleshooting
- Distributor sales and sector training

Please contact your regional office to discuss your training requirements.



WWW.ICENIMARINESERVICES.CO.UK
01203 854999

ICENI MARINE SERVICES

ICENI PRIDE

ICENI MARINE SERVICES



RETROFIT AND REFURBISHMENT

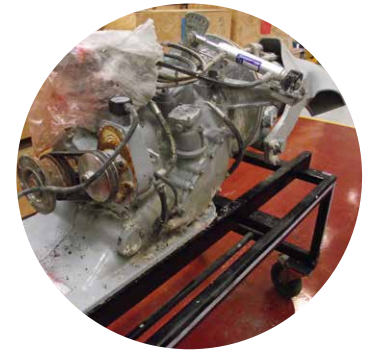

Maximise your vessel performance.

To ensure your vessel is operating optimally for your environment, HamiltonJet offer a series of product upgrades and refurbishments, delivered and guaranteed by our experienced teams.

Retrofit options include:

- Jet upgrades
- Control system upgrades
- Feature enhancements - including JET anchor.



Refurbishment options include:

- Jet inspection reporting and overhaul recommendations
- Complete jet overhauls
- Reverse and steering glider overhauls
- Seal replacements
- Impeller rebuilds
- Impeller leading/tailing edge or bent blade repairs.



OPTIMISATION

It is critical that the marine industry embraces and adapts to the change in global dynamics and the disruptive effects of new technologies, environmental impacts and the need to optimise operations.

Imagine a world where you can have zero emissions, predictable and reliable operations, and improved on board experience for your crew and passengers.

HamiltonJet can help you realise your optimisation ambitions and disrupt your market through electrification, automation and digitisation.

HAMILTON
ELECTRO-HYBRID
DRIVE SYSTEM (EHX)

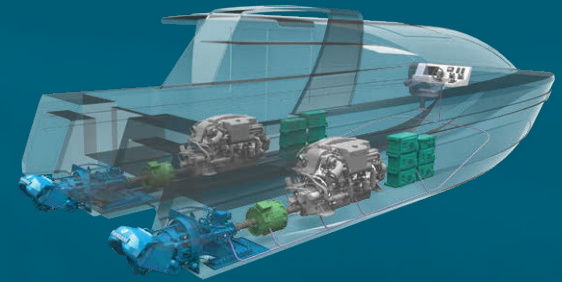

JETsense
Guided by  SEA MACHINES

HAMILTON ADVANCED
SKIPPER ASSISTANCE

ADVANCED ON BOARD
CONTROLS NETWORK



WARRANTY SUPPORT

HamiltonJet products are manufactured, assembled and inspected to the highest standards by our trained factory technicians. We warrant all products we manufacture to ensure you enjoy the best from your HamiltonJet product.

Standard Warranty:

The Warranty Period for HamiltonJet Products is limited to a period of twenty-four (24) months from the date of original shipment from the HamiltonJet factory, or twelve (12) months from the vessel launch date, whichever occurs earliest.

Online Product & Warranty Registration is available on our website.
www.hamiltonjet.com

Extended Warranty:

We can offer extended warranty to meet your requirements following the expiration of our standard warranty.







WORK WITH US

Over the decades we've become trusted partners to boat builders, naval architects and marine operators around the globe. They tell our story better than we do, so if you'd like some references, please get in touch.

Our network is global. Wherever you are, you'll find experienced distributors supported by our own regional office staff to assist you with your project. We'll walk you through the process and can deliver simple or complex projects.

Our market experience is extensive. It covers offshore, pilot, rescue, fire, military, patrol, windfarm, fast ferry, fishing, aquaculture and recreational applications.

HamiltonJet Global Headquarters:

PO Box 709
Christchurch, 8140
NEW ZEALAND
P: 0064 3 962 0530
E: marketing@hamiltonjet.nz
www.hamiltonjet.com

HamiltonJet Regional Offices:

Americas

14680 NE North
Woodinville Way
Suite 100, Woodinville
WA 98072
UNITED STATES
OF AMERICA
P: 001425 527 3000
or 800 423 3509
E: marketing@hamiltonjet.com

EMEA

Unit 26, The Birches
Industrial Estate
East Grinstead,
West Sussex RH19 1XZ
UNITED KINGDOM
P: 00441342 313 437
E: marketing@hamiltonjet.uk

Asia

1 Toh Tuck Link
#04-01
SINGAPORE 596222
P: 0065 65672202
E: marketing@hamiltonjet.sg

