



HJ SERIES
80kW to 900kW



HamiltonJet

HamiltonJet HJ Series waterjets represent the most successful range of waterjet propulsion units available in the world today.

Proven over many years to perform in all operating conditions, the HamiltonJet HJ waterjet range provides superior thrust, efficiency and cavitation performance over other similar sized waterjet models.



The HamiltonJet Promise

Total Waterjet Solutions

With experience spanning six decades, HamiltonJet provides a totally integrated waterjet propulsion solution to the marine industry. From initial enquiry and right through the lifespan of a vessel, HamiltonJet offers a comprehensive customer support package that is second to none.

HamiltonJet has been providing waterjet propulsion solutions to the marine industry since the 1950s, and has installed more than 50,000 waterjets into vessels around the world. Through this experience HamiltonJet understands the wide range of conditions, situations and tasks a modern vessel needs to be able to undertake on a daily basis throughout its operating life.

The company also has more experience with designers and boat builders than any other waterjet manufacturer, and so provides the simplest installation package of any waterjet design in the market today.

Knowledge gained through unrivalled waterjet application experience mean HamiltonJet is able to provide accurate performance predictions to ensure a vessel will deliver on its design criteria. This knowledge and experience is shared globally through HamiltonJet's extensive distributor sales and support network.

Evidence of HamiltonJet's success can be seen in the range of innovative designs the company has pioneered, each raising the standard of waterjet performance, control and lifecycle, all of which build on the HamiltonJet ethos of superior customer support.

Performance = high and low speed power and efficiency, load carrying capability and acceleration.

Control = high and low speed manoeuvrability, course keeping, close quarters manoeuvring and development of innovative control system technology.

Lifecycle = Pre-sales application engineering, simple installation, integrated features and maximum durability.

Customer Support = spare parts supply & advice in country, full spares warehouse & HamiltonJet technical staff in region, installation and commissioning service assistance, and training programmes.

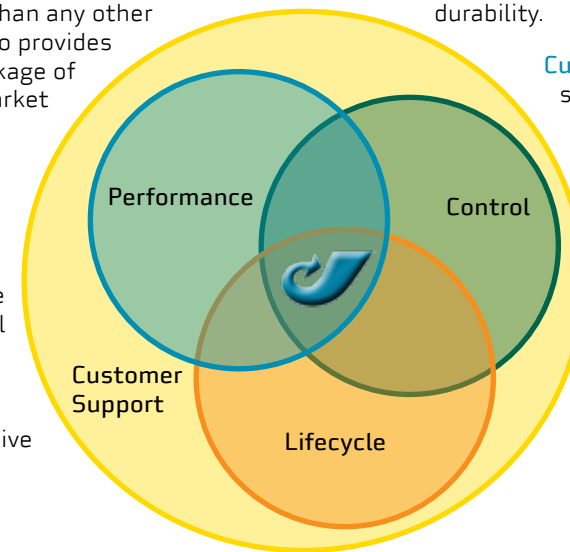

Right: HamiltonJet HJ364 waterjets in production at the company's New Zealand factory.



The Waterjet Advantage

EFFICIENCY

As vessel speed increases waterjets become more efficient compared to conventional propeller systems. Efficiency benefits are due to...

- No appendage drag – the waterjet intake sits flush with the hull bottom without struts, propeller shafts, rudders or any elements protruding beneath the hull to increase hull resistance, particularly as speed increases.
- Thrust generated by a waterjet is parallel to the direction of travel. For many propeller systems the shaft is angled down and thrust is generated in the direction of the shaft, so only a component of the total thrust is in the direction of travel.
- Energy lost from flow rotation is recovered by the stator section of the waterjet. This is energy that is lost in a propeller installation.

MANOEUVRABILITY

Waterjet propulsion provides far superior manoeuvrability at both high and low speeds compared to a propeller boat...

- Waterjet thrust is independent of boat speed – thrust is determined by input power and astern deflector position and is available at all times, even at zero speed. Result – boat can be turned without moving ahead or astern, and the ability to move the reverse deflector slightly either side of the zero speed position also provides very fine ahead or astern control, all while maintaining full steering control.
- No need to change engine rotation to generate reverse thrust. A change from full forward thrust to full reverse thrust only requires the reverse duct to move from fully up to fully down position.
- Sideways thrust capability with two or more jets (with split duct reverse deflectors) without the need for a bow thruster.



SAFETY

Waterjets have no exposed high-speed moving components external to a vessel's hull, providing greater safety to people in the water and marine life, and allowing the propulsor to keep running when operating in such conditions. There is also less risk to equipment in the water.

DURABILITY

A waterjet is inherently more durable than conventional propeller propulsion...

- No exposed appendages beneath the hull – allows the vessel to access shallow waterways, cross sandbars and reefs, and complete beach landings and launches.
- The impeller is protected inside the body of the jet – propulsion gear is not exposed to damage from floating debris or in the event of grounding.
- Maintenance can be predicted and planned in advance – with propeller systems there is always uncertainty as exposed propulsion gear could be damaged at any time. Waterjets reduce downtime for vessel maintenance and can mean fewer vessels are required in a fleet.



FLEXIBILITY

Waterjets offer significant advantages for vessels subject to variable loads...

- Boat speed is determined by hull weight – when the vessel is running light it will travel faster or maintain service speed with reduced power input, resulting in fuel and time savings.
- Engines can not be overloaded when vessel is heavily laden – unlike propeller systems which can transfer load to the engine, a waterjet will always match available engine power. This results in less engine wear and consequently less maintenance and longer engine life.
- Secondary propulsion option – waterjets can be used as boost or loiter propulsion alongside other waterjets or propellers.

Right: The twin jetstreams of this patrol vessel in Spain are delivered from a pair of HamiltonJet HJ403 waterjets.



The HamiltonJet Difference

PERFORMANCE

High speed performance and efficiency – advanced impeller and intake designs provide peak efficiency and performance over a wide speed range.

Low speed performance – high thrust at low speeds ensures excellent station-keeping, bollard pull, load carrying and manoeuvring.

Acceleration – ability to apply full power at lower speeds ensures fast acceleration for patrol boats, rescue craft, pilot boats and recreational vessels.

CONTROL

Steering control – HamiltonJet's JT steering system out-performs all others, reducing thrust losses when steering to give tighter turns and maintain vessel speed during the turn.

Ahead / Astern control – HamiltonJet's split duct reverse deflector provides up to 60% of forward thrust, resulting in highly responsive control at slow boat speeds where engine is set to higher than idle RPM and the reverse duct is used to regulate forward and aft thrust.

Speed of the controls response – HamiltonJet controls respond quickly to skipper input to improve manoeuvring control and safety. The company develops hydraulic and electronic control systems to maximise control benefits of its waterjets.

LIFECYCLE

Material specifications – all HamiltonJet waterjets are manufactured using high quality materials to ensure the best mix of durability, weight, corrosion resistance and cost.

Impeller rating accuracy – impellers are cast as a single piece to ensure more accurate ratings for all impellers and a better match to peak engine rating.

Application engineering – HamiltonJet provides the highest level of technical expertise and advice to builders, designers and end users throughout the entire vessel design, build and commissioning phases, and for the operational life of a vessel.

Integrated Engineering – Each HamiltonJet waterjet is a complete packaged, factory tested, propulsion module, with reverse and steering control systems fully integrated with the jet to simplify installation and maintenance.

SUPPORT

International Support – HamiltonJet's service and support network extends around the globe to provide immediate assistance and spare parts supply.

HamiltonJet Features

Integral jet-driven hydraulic pump and control system (JHPU) assembly. No need for additional pumps and plumbing to be fitted.

Inboard thrust bearing assembly transfers thrust forces to intake block and hull bottom, not transom, so no additional hull or transom reinforcing is required.

All hydraulic components are mounted inboard where they are protected from corrosion and marine growth.

Driveshaft coupling flange. Can be direct driven or connected via a gearbox. No difficult engine alignment problems.

Intake block, including protective screen bars, is supplied ready to mount in hull. This hydrodynamically designed intake ensures optimal flow of water to the impeller while the screen protects the pump from damage due to ingested material, without adversely affecting waterflow into the jet unit. A rake can be fitted to help remove blockages from the screen bars if vessel is operating in weed-laden or polluted waterways.

Integral hydraulic oil cooler.

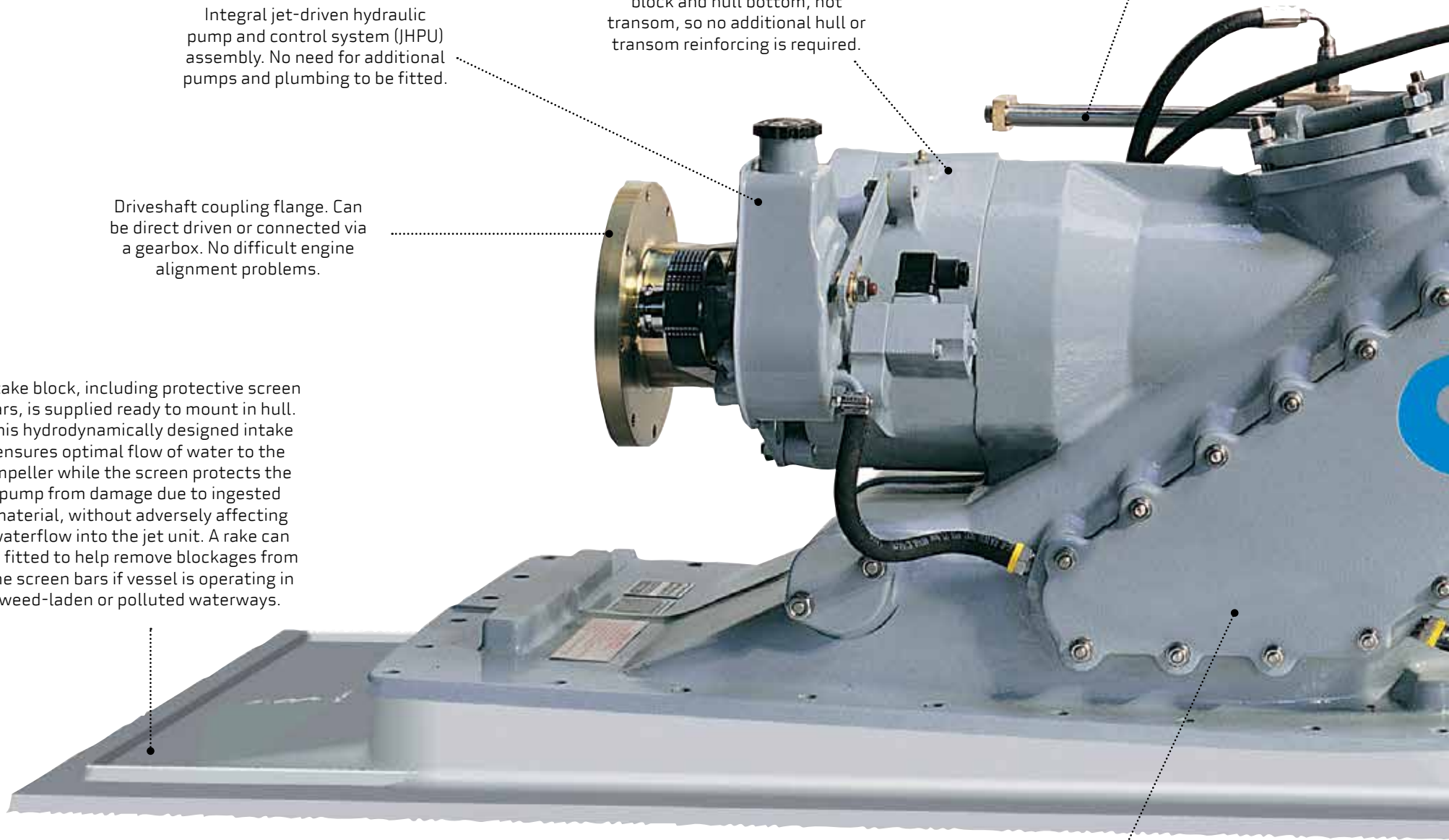

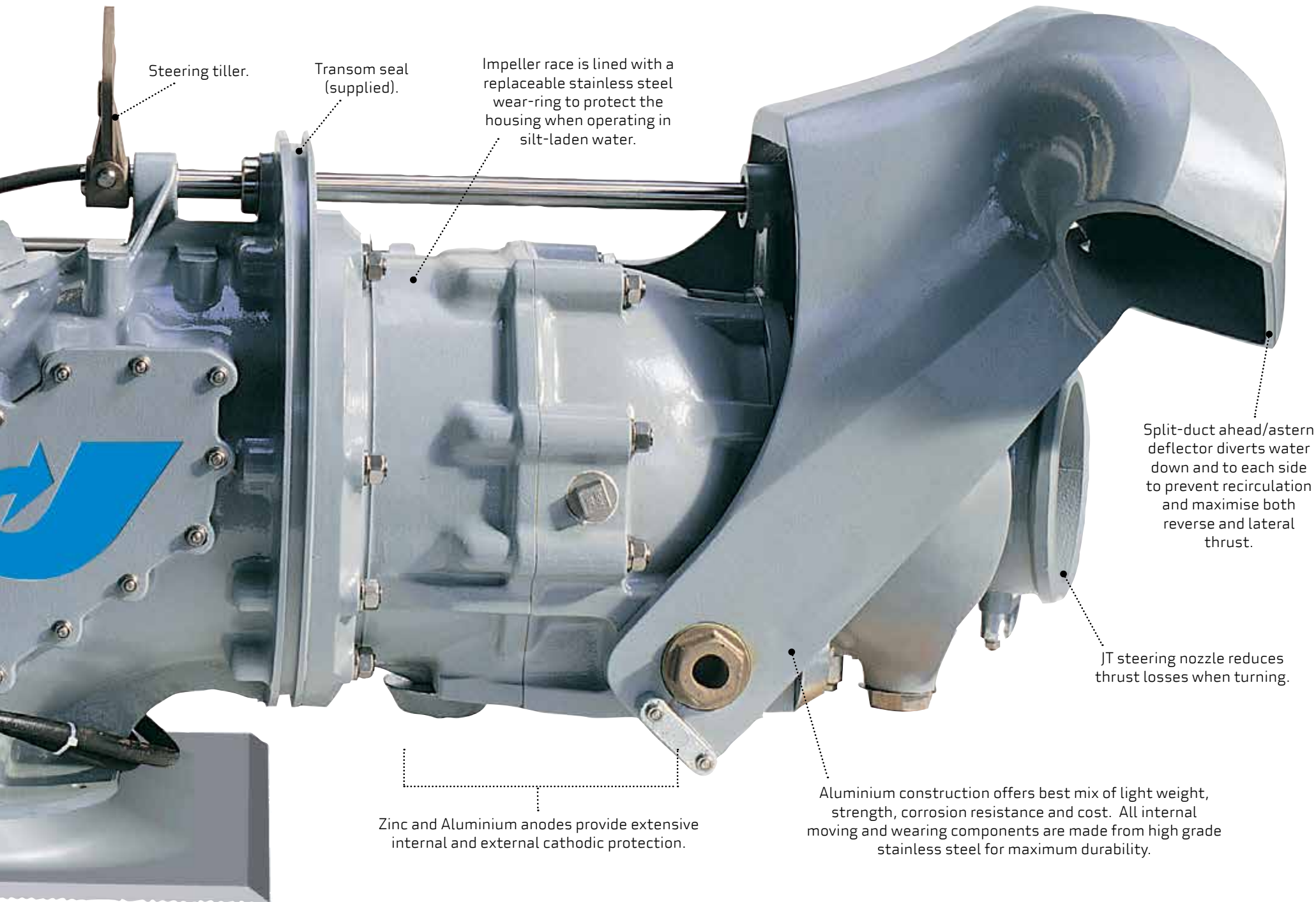

Steering tiller.

Transom seal (supplied).

Impeller race is lined with a replaceable stainless steel wear-ring to protect the housing when operating in silt-laden water.

Split-duct ahead/astern deflector diverts water down and to each side to prevent recirculation and maximise both reverse and lateral thrust.

JT steering nozzle reduces thrust losses when turning.

Zinc and Aluminium anodes provide extensive internal and external cathodic protection.

Aluminium construction offers best mix of light weight, strength, corrosion resistance and cost. All internal moving and wearing components are made from high grade stainless steel for maximum durability.

HamiltonJet HJ Series Dimensions

The HJ Series comprises a range of highly efficient waterjet units suitable for propelling craft at speeds ranging from zero to up to 50 knots and typically of length up to 20 metres.

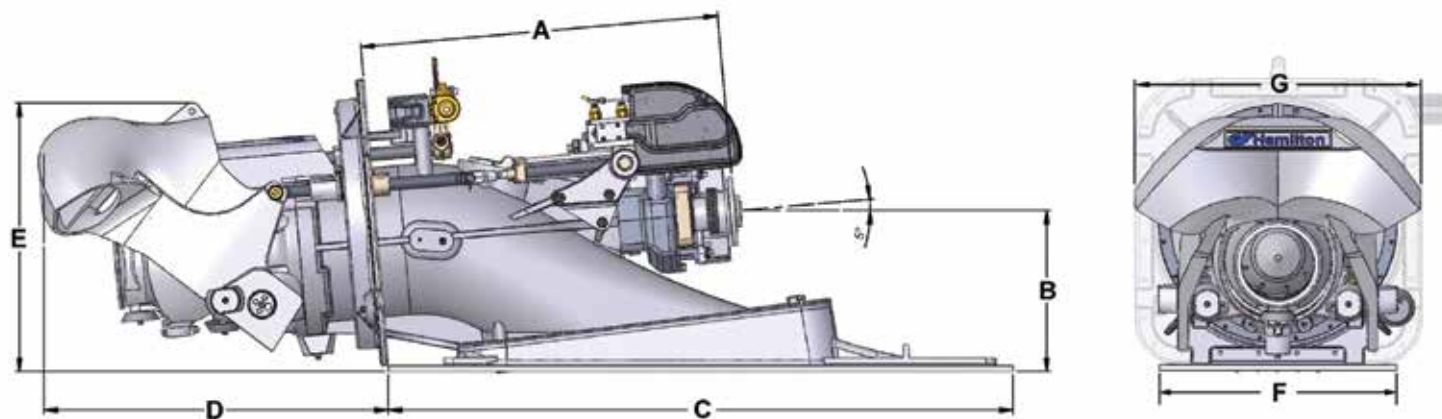

Jet Model	A (mm)	B (mm)	C (mm)	D (mm)	E (mm)	F (mm)	G (mm)	Intake Block (kg / lbs)	Dry Weight (kg / lbs)	Entrained Water (kg / lbs)
HJ212	450.3 ^a	252	762	609	440	386	450	7 / 15.4	75 / 165	17 / 37
HJ213	413	249	762	609	420	386	450	7 / 15.4	84 / 185	17 / 37
HJ241	424	284	829	705	491	431	502	10 / 22	104 / 229	26 / 57
HJ274	570	302	1100	710	548	470	608	22 / 48.5	152 / 335	35 / 77
HJ292	681	330	1180	750	550	495	608	26.4 / 58	187 / 412	45 / 99
HJ322	866	371	1380	835	637	550	680	37 / 82	260 / 573	62 / 137
HJ364	937	420	1634	901	709	621	747	62 / 137	408 / 899	79 / 174
HJ403	1053	474	1723	1080	752	690	904	72 / 159	641 / 1407	110 / 243

NOTES: Input RPM are subject to suitable cavitation limits – lower RPM figure is always preferred. Higher power inputs will restrict input RPM range.

^a – HJ212 “A” dimension is to the end of a splined shaft. May be close coupled.

Weight based on standard 5° Intake Block option. Contact HamiltonJet for weights of optional 0° intake.

Layout and dimensions shown are indicative only for initial design purposes, based on jets with standard 5° intake block which facilitates close direct drive coupling of the engine. An optional 0° intake block, which positions the jet parallel to the hull bottom, is available for certain models. Consult HamiltonJet for more detailed information.

Right: Kvichak-built US Navy Maritime Prepositioning Force (MPF) high speed landing barge. Twin HamiltonJet HJ364 waterjets.





HamiltonJet HJ Series Power / RPM Curves

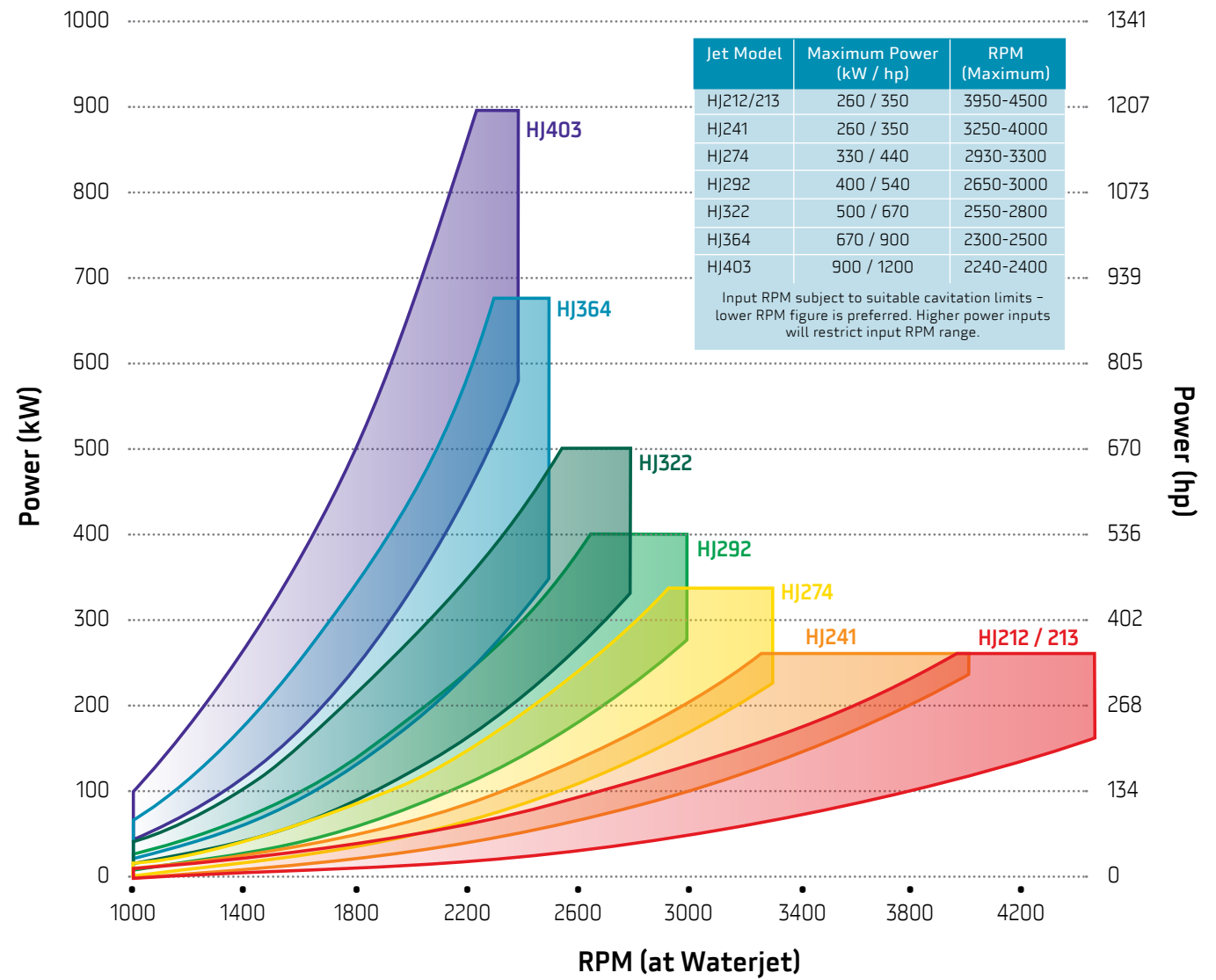

Note: Waterjet selection is determined by a range of hull and operational factors, most importantly vessel size and displacement (weight), and not necessarily by matching the above specifications to the desired engine power/RPM curve. In all cases you should consult HamiltonJet for assistance with waterjet selection.



HamiltonJet Operation

JT Steering

All HJ Series waterjets incorporate HamiltonJet's JT steering nozzle to optimise both steering efficiency and delivery of propulsive thrust. Compared with other waterjet steering systems, the JT nozzle provides outstanding steering response at all boat speeds. This is particularly noticeable at low speeds due to the absence of a central "deadband". The design reduces nozzle flow disturbance, resulting in lower energy losses and minimal loss of forward thrust when steering. These factors mean higher overall efficiency through improved course-keeping and, coupled with low steering loads and noise level, make the JT system highly effective and reliable under all conditions.

Ahead / Astern

The ahead/astern function is an integral part of HJ Series waterjets, utilising a split-duct deflector to provide maximum astern thrust under all conditions of boat speed, water depth and throttle opening. The splitter incorporated in the deflector divides the flow to two outlet ducts angled down to clear the transom and to the sides to retain the steering thrust component. Vectoring the astern thrust away from the jet intake avoids recirculation and the resulting astern thrust is equivalent to up to 60% of ahead thrust - maintainable up to high throttle settings.

The shift from full ahead to full astern is a smooth transition as the deflector is lowered through the jetstream, eliminating any delay or shock loading normally associated with propeller/gearbox drives. Designed to withstand the loads imposed when the deflector is lowered at full speed ahead, the arrangement provides a powerful braking function for emergencies.

The separation of the steering and ahead/astern functions offer the opportunity for unlimited combinations of translational and rotational movements for outstanding vessel control.

Control Functions

Since steering and ahead/astern functions are separate and have independent effects, they may be used together to enable complex vessel manoeuvres without complex combinations of control inputs by the operator.

With the astern deflector fully raised, full forward thrust is available. With the deflector in the lower position, full astern thrust is generated. In both positions full independent steering is available for rotating the craft. By setting the deflector in the intermediate "zero-speed" position, ahead and astern thrusts are equalised for holding the craft on station, but with independent steering effect still available for rotational control. Infinitely variable adjustment either side of "zero-speed" enables the craft to be crept ahead or astern, and in multiple jet installations appropriate thrust vectoring alone can be used to induce true sideways movement.

Control Systems

All HamiltonJet waterjets incorporate a hydraulic or electronic control system specifically designed to best match the characteristics of the particular vessel and waterjet configuration. Hydraulic components are built into the waterjet and can be actuated from the helm by either manual cables (smaller HJ models only), a hydraulic control system or HamiltonJet's blue ARROW and MECS electronic control systems (for HJ292 - HJ403 only).

Electronic control systems offer a greater level of customization to suit a wide range of operational parameters, including combined or separate throttle & reverse control, multiple control stations, interface with other electronic helm components such as autopilots and DPS, and improved operator interface to ensure skippers of all levels of experience have full access to the manoeuvring capabilities and advantages of HamiltonJet waterjets.

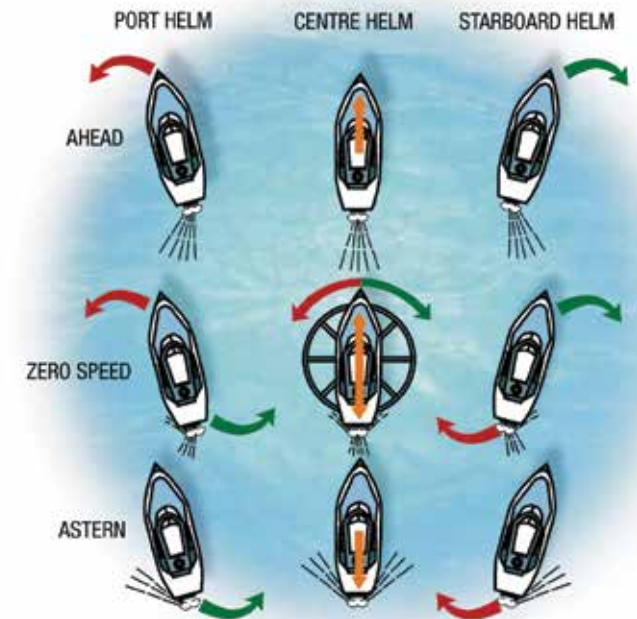

HamiltonJet Suitable Hull Form Guidelines

This page provides basic information to assist when determining the suitability of waterjet propulsion for different hull forms, vessel applications and performance expectations.

General Guidelines

The hull shape, monohull or multihull, should be that which best suits the size, displacement and cruising speed of the craft, but with the following prerequisites:

- Hull shape and appendages must avoid entraining air into the waterjet inlet.
- If no keeling is proposed, hull shape must be directionally stable without such appendages.
- Avoid appendages such as keels, rudders, planing strakes, etc for at least 2 metres in front of the waterjet intake. Appendages can generally be placed to the outside of the projected area forward of the waterjet inlet(s) without affecting their performance.
- Water level must be at least up to the waterjet mainshaft when the craft is at rest.
- HamiltonJet should be consulted in all cases before construction starts.

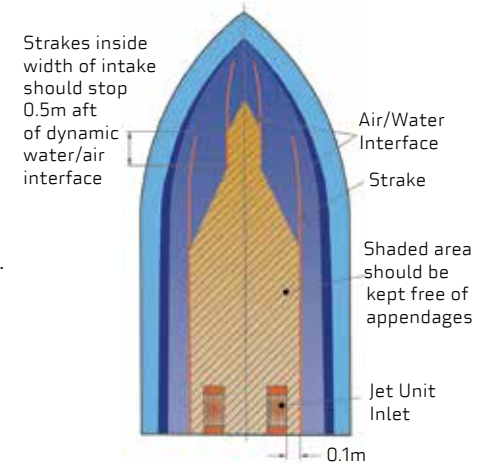

High ("Planing") Speed Craft (over 30 knots)

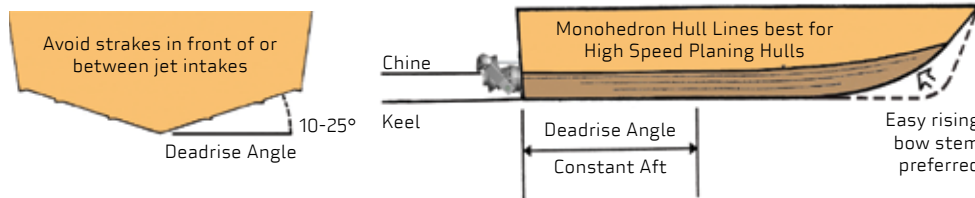

For best directional stability and speed, a hull with monohedron lines (constant deadrise over planing area) is recommended.

Avoid deep and fine bow stems as, without additional keeling, these can cause directional instability at speeds over 25 knots. Also for directional stability and to avoid air being entrained into the waterjet from bow waves, deadrise angles of between 10° and 25° are generally recommended.

Multihulls and Medium Speed Craft (10 to 30 knots but increasing with length)

- Long narrow multihulls, which maintain low trim angles throughout the speed range, are well suited to waterjet propulsion. To minimise hull resistance of catamarans, designers should compensate for lost buoyancy aft caused by waterjet installation, generally by keeping the Longitudinal Centre of Gravity (LCG) well forward.
- Surface Effect Ship concept hulls and foils can provide additional 'lift' to the hull and give significant reduction in resistance, but care must then be taken to avoid aerated water from the bows and foils entering the waterjet(s).
- For medium speed craft (eg: semi-displacement and warped hulls) ensure sufficient immersion for waterjet(s) to prime when craft is at rest and LCG is positioned for best speed.

Note: Due to moderate dead rise and immersion aft and deeper vee forward sections, some keeling aft may be required to maintain directional stability.

Slow Speed Craft (0 to 10 knots but increasing with length)

- Craft speed is limited by the water line length (WLL or LWL) and efficient hull shape rather than shaft power.
- At speeds up to the natural displacement speed (NDS), very modest shaft power is required and acceptable propulsive efficiencies can thus be obtained with relatively small waterjets.

In all situations we recommend you submit the Application Questionnaire form on the reverse and then discuss your propulsion options with a HamiltonJet authorised Distributor to ensure waterjets are successful in your vessel.



This Questionnaire is for checking intended hull shape and speed are suitable for waterjets and to initially select the best HamiltonJet propulsion option for it. Note that the more information provided, the greater the accuracy with which an appropriate propulsion system can be selected. All information provided will be treated as confidential. *The MOST IMPORTANT INFORMATION and units of measure are in red.*

Project Reference

Date: _____

1. Project Reference: _____ **Approx. hours/day at full power:** _____ hrs/day

2. Vessel Use: _____ **Expected operating hours / year (to nearest 1000 hours):** _____ hrs/yr

3. Company: _____ **Contact Name:** _____

4. Country: _____ **Tel. No:** _____ **Email:** _____

Hull Description

Hull Construction Material: Aluminium Wood GRP Steel Other: _____

5. Hull Type: Monohedron Monohull Warped Monohull Catamaran* Other*: _____

Planing Semi-Displacement Displacement Barge/Landing Craft

Hard Chine Round Bilge RIB / RHIB Other: _____

Note any other distinguishing hull bottom features or appendages (eg: lifting foils, planing strakes): _____

Hull Details please specify units of measure

metres feet tonne (metric) ton (UK/long) ton (US/short) kg lbs

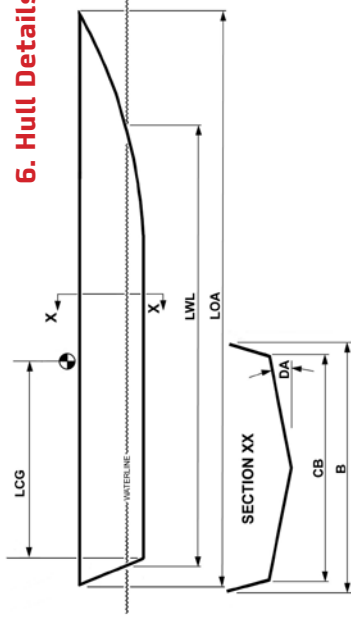

If available please provide:

Hull General Arrangement drawings Hull line drawings

6. Hull Details: LOA (Overall Length): _____

LWL (Waterline Length): _____

LCG (Longitudinal Centre of Gravity at **max.** displacement): _____

B (Beam Overall): _____

CB (Chine Beam): **Max:** _____ and **at transom:** _____

DA (Deadrise Angle): @mid LWL: _____ ° DA@Transom: _____ °

Height (above WL for wind resistance allowance): _____

Displacement: Maximum: _____ LCG: _____

Include LCG for each displacement state if known **Light:** _____ LCG: _____

Trials (if available): _____ LCG: _____

Expected Design Performance

7. Vessel Speed with Maximum Power Input (knots): _____ Vessel Speed with Continuous Power Input (knots): _____

at Maximum Displacement: _____ knots at Maximum Displacement: _____ knots

at Trials Displacement: _____ knots at Trials Displacement: _____ knots

at Light Displacement: _____ knots at Light Displacement: _____ knots

Seastate: _____ Seastate: _____

Attach Hull Resistance Data* (if available): Estimated Model Tested incl. allowances for: Wind Waves

Proposed Engine(s)

Engine Configuration: _____ Make: _____ Model: _____

8. Power: Maximum: _____ kW bhp mhp @ _____ rpm

Continuous: _____ kW bhp mhp @ _____ rpm

Above ratings are: Nett Flywheel Power (ie: before gearbox, etc) or Nett Shaft Power (ie: waterjet input)

9. Gearbox: No/Direct drive Yes, **Make & Model:** _____ **Ratio:** _____ :1

* For catamarans and other multihull vessels, please provide total hull resistance

Complete this form, then return to your local HamiltonJet Distributor or Regional Office by email, fax or post.

See back page of this brochure for contact details.

This questionnaire is also available in electronic/email format from www.hamiltonjet.co.nz.

WORLD HEADQUARTERS

HamiltonJet Global

PO Box 709
Christchurch
New Zealand
Phone: +64 3 962 0530
Fax: +64 3 962 0534
Email: marketing@hamjet.co.nz
www.hamiltonjet.co.nz

REGIONAL OFFICES

HamiltonJet Americas

14680 NE North Woodinville Way
Suite 100
Woodinville WA 98072
United States of America
Phone: +1 425 527 3000
Toll Free: 800 423 3509
Fax: +1 425 527 9188
Email: marketing@hamiltonjet.com
www.hamiltonjet.com

HamiltonJet Europe

Unit 26, The Birches Industrial Estate
East Grinstead
West Sussex RH19 1XZ
United Kingdom
Phone: +44 1342 313 437
Fax: +44 1342 313 438
Email: marketing@emea.hamiltonjet.com

HamiltonJet Asia

1 Toh Tuck Link
#04-01
Singapore 596222
Phone: +65 6567 2202
Fax: +65 6567 4788
Email: hamiltonjet.asia@hamjet.co.nz

Your local HamiltonJet Distributor is...

Cover: blue ARROW Rescue, Christchurch, New Zealand. Twin HamiltonJet HJ322 waterjets.

